

Survey on Dust Network and Energy Efficiency Communications in Wireless Sensor Network

Suvendra Kumar Jayasingh

Asst. Prof, Department of Computer Science, IMIT, BOSE Campus, Cuttack-753007, Odisha, India.

Abstract –Recent technological innovations made in electronics and wireless communications have fostered the development of wireless sensor networks (WSNs). A WSN typically consists of many small, low cost, low-power communication devices called sensor nodes. But Dust Networks, a pioneer in the field of wireless sensor networking, is defining the way to connect smart devices. Dust Networks delivers reliable, resilient and scalable wireless products with advanced network management and comprehensive security features. Thousands of Dust-enabled networks have been deployed around the globe, securely connecting a wide variety of smart devices to applications that are delivering on the promise of a smarter, greener, more efficient planet. In wireless sensor network, there are two types of sensor nodes as a representative single hop heterogeneous network. For multi-hop homogeneous networks (sensor nodes use multi-hopping to reach the cluster head), we propose and analyze a multi-hop variant of LEACH that we call M-LEACH. We show that M-LEACH has better energy efficiency than LEACH in many cases.

Index Terms –Distributed network(DN), wireless sensor networks (WSN), Dust Networks(DNs)

1. INTRODUCTION

Today, a computer network is a set of nodes connected together for the purpose of sharing resources. The most common resource shared is connection to the Internet. The DN is a term used for a network structure which its specific feature is distribution of the network resources (such as switching equipment and processors) on different geographical area in the sense of size, that these networks are working in. Many examples of DNs can be seen around us, like the phone networks. Even there are some examples of natural DNs, such as a network of people who are working on the same subject but they are spread in a geographical area or a DN of animals. Internet has grown incredibly fast from the time it has started to develop as DARPA net in 1960. Now Internet is a huge network which connects the world together. More than hundred countries in the world are now connected through Internet and more than a quarter of world population using it regularly in their daily life. The Distributed network is the basis for lots of different networks, in which each has the basic structure of distributed networks with some different features and special usage. One of the most interesting research areas which also belong to this category of networks is distributed sensor networks that have a vast and interesting range of applications.

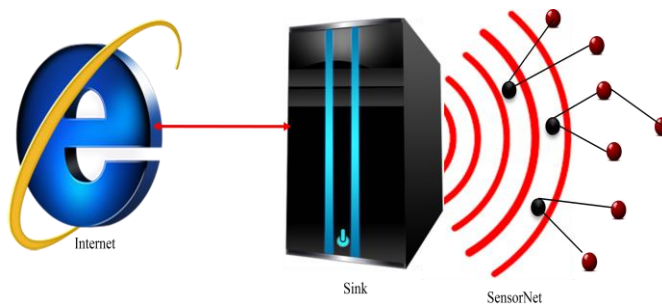

Figure 1 The general view of a distributed sensor network.

1.1. WSN

A WSN is a collection of sensor nodes organized into a cooperative network. Each node consists of processing capability (one or more microcontrollers, CPUs or DSP chips), may contain multiple types of memory (program, data and flash memories), have a RF transceiver (usually with a single omni-directional antenna), have a power source (e.g., batteries and solar cells), and accommodate various sensors and actuators. The nodes communicate wirelessly and often self-organize after being deployed in an ad-hoc fashion. Systems of 1000s or even 10,000 nodes are anticipated. Such systems can revolutionize the way we live and work.

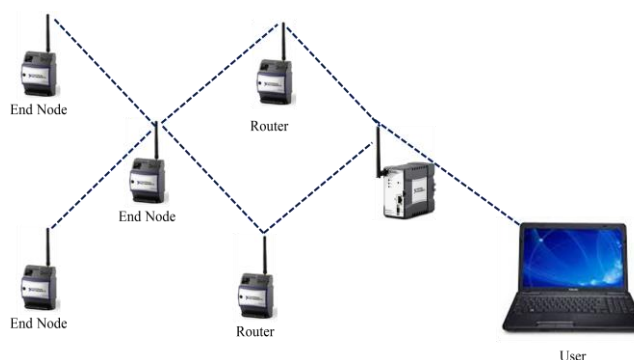

Figure 2 The overall view of WSN.

1.2. DNs

The DNs is a pioneer in the field of WSN, and is defining the way to connect smart devices. Using standards-based network technology. DNs provide reliable, resilient and scalable products with advanced network management and

comprehensive security features. DNs have dominated the field of WSN technology in industrial applications. The dust announced a new product line that preserves key features of their industrial products, but is targeted to serve both commercial and industrial applications, and to extend their market leadership beyond the industrial space. The figure 3 had shown the DNs.



Figure 3 The DNs.

In [1], the history of DNs shown in Table 1.

Year of Development	Name of Technologist
July 2002	Company Founded by Kris Pister and Rob Conant.
February 2002	Pister takes leave from UC Berkeley to work at Dust Networks full time.
January 2003	Series A funding of \$7Million.
August 2004	First SmartMesh product officially shipped
December 2004	Kris Pister returns to UC Berkel
January 2005	Series B funding of \$22Million

Table 1 The History of DNs.

2. COMPARISON BETWEEN DNS AND WSN

It was founded in 2002 by Kris Pister and Rob Conant, Dust Networks provides low-powered wireless sensor networks to solution providers, integrators, and OEMs for monitoring and controlling applications.

A WSN is a wireless network of small computers with sensors and actuators. These small computers are called motes and they are composed of three principle parts: a sensor or actuator, a microprocessor, and a radio chip.

The sensor reads physical data of the real world, the actuator can control basic functions like turning off a light or changing a room temperature, the microcontroller processes data from the sensor and makes decisions, and the radio chip communicates data wirelessly.

The next element of the network is the Smart Manager that collects all the information from the motes and acts as a gateway between them and the server. Throughout the network and on the server there is software that executes routing, timing, network optimization and management functions to ensure that connectivity and long-term reliability.

The DNs' proven, low power WSN technology extends Linear's product portfolio into key growth areas in industrial process control, data acquisition and energy harvesting. DNs' ultralow power wireless systems complements Linear's analog and digital sensor interface ICs, and energy harvesting power management products in applications where measurement of physical parameters has traditionally been impractical or impossible. Erik Soule, Vice President of Signal Conditioning and High Frequency products for Linear Technology, stated, "DNs offers the lowest power radio technology and most complete networking software for building industrial-grade wireless sensor networks. Combined with Linear's precision low-power sensor interface products and battery-free energy harvesting technology, we can now offer the industry's highest performance remote monitoring solutions." With the growing importance of machine-to-machine communications to enable remote data acquisition, low power wireless sensing is an emerging solution for many end markets, including industrial process control, building automation and data center energy management. Joy Weiss, President of DNs, stated, "Dust Networks and Linear are an excellent fit. We already have very complementary products and customers, and with Linear's global sales reach we can be at the forefront, enabling sensor networks to go wireless on an even broader scale." "Smart Dust" was first conceived by Dr. Kris Pister, founder and chief technologist of Dust Networks, as a simple way to deploy intelligent wireless sensors. DNs pioneered SmartMesh networks that comprise a self-forming mesh of nodes, or "motes," which collect and relay data, and a network manager that monitors and manages network performance and sends data to the host application. This

technology is now the basis for a number of seminal networking standards. The hallmark of Dust Networks' technology is that it combines low power, standards-based radio technology, time diversity, frequency diversity, and physical diversity to assure reliability, scalability, wire free power source flexibility, and ease-of-use. All motes in a SmartMesh network even the routing nodes are designed to run on batteries for years, allowing the ultimate flexibility in placing sensors exactly where they need to go with low cost "peel and stick" installations.



Figure 4 The Smartmesh Ip Managers And its Chip Antenna.

3. STYLING SMART MESH NETWORK

The Redundant routing is a must have in a real world RF application. A full mesh topology with automatic node joining and healing lets the network maintain long-term reliability. It works without special-purpose routers. Its implementation in the Kaye product line allows up to 100 sensor nodes to be connected in a seamless, reliable and self forming mesh network.

The mesh technology permits nodes to communicate with the base station and each other, correcting for weak RF links and automatically adjusting to dynamic RF environment, e.g. a forklift truck driving into a warehouse blocking a signal. No special knowledge or expertise is required to install or operate the Kaye RF ValProbe.

The Key Features of Smart-Mesh Network:

- **Transmission Reliability:** RF Mesh can provide up to 99.9% transmission reliability. Redundancy introduced through data-storage eliminates risks of data loss.

- **Dynamic Network Formation:** No RF Site surveys required. System works out of the box and is fully validatable.
- **Low Energy Consumption.**
- **Data Security:** Immune to RF interference, snooping, insertion of invalid data. Dust's portfolios of standards-based products include.

3.1. SmartMesh IP

SmartMesh IP is built for IP compatibility, and is based on 6LoWPAN and 802.15.4e standards. The SmartMesh IP solution is widely applicable and cost effective and enables low power consumption even in harsh, dynamically changing RF environments. The SmartMesh IP is shown in figure.01. SmartMesh IP wireless sensor networks are self managing, low power Internet Protocol networks built from wireless nodes called motes. The LTP5901-IPM is the IP mote product in the Eterna family of IEEE 802.15.4e printed circuit board assembly solutions, featuring a highly-integrated, low power radio design by Dust Networks as well as an ARM Cortex-M3 32-bit microprocessor running Dust's embedded SmartMesh IP networking software. The LTP5901-IPM includes an onboard chip antenna and comes with modular RF certifications. Also available are the LTC5800-IPM Mote-on-Chip and the LTP5902-IPM module which includes an MMCX antenna connector.

With Dust's time-synchronized SmartMesh IP networks, all motes in the network may route, source or terminate data, while providing many years of battery powered operation. The SmartMesh IP software provided with the LTP5901-IPM is fully tested and validated, and is readily configured via software Application Programming Interface.

SmartMesh IP motes deliver a highly flexible network with proven reliability and low power performance in an easy-to-integrate platform in [2].

3.2. SmartMesh WirelessHART

SmartMesh WirelessHART wireless sensor networks are self managing, low power networks built from wireless nodes called motes. With Dust's time-synchronized SmartMesh WirelessHART networks, all motes in the network may route, source or terminate data, while providing many years of battery powered operation. SmartMesh WirelessHART products are designed for the harshest industrial environments, where low power, reliability, resilience and scalability are key, making them well suited for general industrial applications as well as WirelessHART-specific designs. SmartMesh WirelessHART complies with the WirelessHART (IEC 62591) standard, offers the lowest power consumption in its class and is the most widely used WirelessHART product available in [3].

3.3. Dust Network Application

In [4], the Dust network attempted to demonstrate that a complete sensor/communication system could be made of sensors one cubic millimeter in size. This involved advances in miniaturization, integration, and energy management. The project focus was independent of any particular sensor, and looked at both commercial and military applications including:

Defense-related sensor networks such as battlefield surveillance, treaty monitoring, transportation monitoring, and scud hunting.

- Virtual keyboard sensors: by attaching miniature remotes on each fingernail, accelerometers could then sense the orientation and motion of each fingertip, and communicate this data to a computer in a wristwatch.
- Inventory control: by placing miniature sensors on each object in the inventory system (product package, carton, pallet, truck warehouse, internet), each component could "talk" to the next component in the system. This evolved into today's RFID inventory control systems.
- Product quality monitoring: temperature and humidity monitoring of perishables such as meat, produce, and dairy.

Impact, vibration and temperature monitoring of consumer electronics, for failure analysis and diagnostic information, e.g. monitoring the vibration of bearings to detect frequency signatures that may indicate imminent failure.

4. ENERGY EFFICIENT COMMUNICATION

In MEMS technology, Microsensor networks is dedicated networks with various distinguishing characteristics are high node density, low data rate, and an unprecedented attention to energy consumption. To develop an energy efficient protocol stack for microsensors requires a network protocol, MAC (Media Access Control) layer, and radio. Energy consumption characteristics are unique to the wireless systems must be addressed and exploited for maximally energy-efficient communication. Traditionally, communication protocols are dedicated networks for multi-hop routing to improve the high path losses incurred by radio transmission. Generally, there are two routing methodologies that are source routing and distance vector approaches in wired networks. Source routing is specified for hop-by-hop paths for each packet and distance vector protocols maintain only next-hop information to each destination. Typically, these protocols are intended for wireless IP (Internet Protocol) applications rather than microsensor networks. Specifically, the protocols have been designed for energy-constrained sensor networks. Directed transmission relies on local interactions among nodes to create efficient paths for data flow. No global routing state is

kept anywhere in the system; rather, each node chooses its own source(s) from which to receive data, leading to reasonably efficient data propagation at a global level. LEACH (Low-Energy Adaptive Clustering Hierarchy) forms rotating clusters of adjacent nodes, within which nodes transmit to a single cluster head that bears the burden of a long-distance transmission. Clustering explicitly the network. Thus there are two importance characteristics of a sensor network that are the lower hardware cost, and uniform energy drainage. In clustering approach, sensor networks can be classified into two broad types

- Single hop network.
- Multi hop network.

5. THE RADIO MODEL

The sensor node consists of four major components a data processor unit, a microsensor, a radio communication subsystem that consists of transmitter or receiver electronics, antennae, and an amplifier; and a power supply unit shown in figure 5 [5].

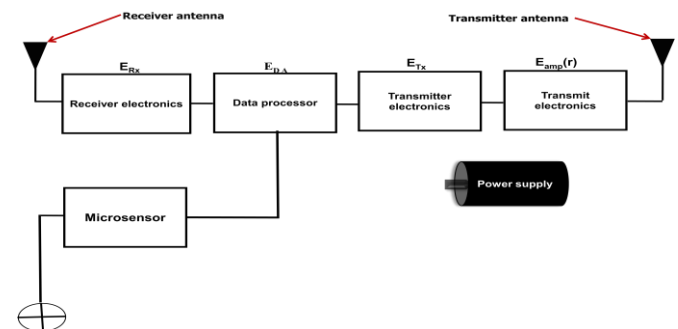

Figure 5 Sensor node consists of four components and associated energy parameter.

The energy is dissipated in all of the first three components of a sensor node which mainly consider the energy dissipations associated with the radio component. In energy efficient, the network layer protocol to improve network lifetime and energy dissipated during data aggregation in the cluster head nodes is also taken into account. In the radio model analysis, we use the same discussed in [6]. The transmit and receive energy costs for the transfer of a k-bit data message between two nodes separated by a distance of d meters is given by equations 1 and 2, respectively.

$$E_T(k, d) = E_{Tx}k + E_{amp}(d)k \quad (1)$$

$$E_R(k) = E_{Rx}k \quad (2)$$

Where $E_T(k, d)$ in equation 1 denotes the total energy dissipated in the transmitter of the source node, and $E_R(k)$ in equation 2 represents the energy cost incurred in the receiver

of the destination node. The parameters E_{Tx} and E_{Rx} in equations 1 and 2 are the per bit energy dissipations for transmission and reception, respectively. $E_{amp}(d)$ is the energy required by the transmit amplifier to maintain an acceptable signal to noise ratio in order to transfer data messages reliably. As per [6-7], we use both the free-space propagation model and the two ray ground propagation model to approximate the path loss sustained due to wireless channel transmission. Given a threshold transmission distance of d_0 , the free-space model is employed when $d \leq d_0$, and the two-ray model is applied for cases where $d > d_0$. Using these two models, the energy required by the transmit amplifier $E_{amp}(d)$ is given by

$$E_{amp}(d) = \begin{cases} \epsilon_{FS}d^4, & d \leq d_0 \\ \epsilon_{FR}d^4, & d > d_0 \end{cases} \quad (3)$$

Where ϵ_{FS} and ϵ_{TR} denote transmit amplifier parameters corresponding to the free space and the two ray models, respectively, and r_0 is the threshold distance given by

$$d_0 = \sqrt{\epsilon_{FS} / \epsilon_{TR}} \quad (4)$$

- To evaluate the performance of homogeneous sensor networks,
- To evaluate the performance of heterogeneous sensor.

The simulation of both heterogeneous sensor networks and homogeneous sensor network is carried out by using MATLAB. The energy consumption is calculated for various numbers of nodes (100-1000). The parameters used in this simulation are given in Table 2

SIMULATION PARAMETERS	Values
Energy consumed by amplifier to transmit shorter distance (μ_1)	42pJ/m ²
Energy consumed by amplifier to transmit longer distance (μ_2)	5.46 pJ/m ⁴
Energy spent to transmit and receive signal (E_f)	0.21mJ
Number of nodes (n_0)	100 to 1000
Optimum number of clusters (m_1)	10 to 100
Area of the network (A)	500mX500m
The energy spent in the transmitter electronics circuit ($l_1 = l_2$)	0.21mJ
Distance from the base station (d)	125m

Table 2 Simulation parameters.

- To Evaluate The Performance of Homogeneous Sensor Networks

In the homogeneous sensor networks, the total energy consumption is obtained by combining the energy consumed by cluster heads and non-cluster heads. Thus, the total energy consumed by homogeneous sensor networks is given by

$$E = T \left(2l_1 + E_f + \frac{m_1 \mu_2 d^4}{n_0} + \frac{\mu_1 A^2}{2m_1} \right)$$

A is the radius of the region, l_1 is the energy spent in the transmitter electronics circuit within a cluster, μ_1 is the energy spent in the RF power amplifier within the cluster, μ_2 is the energy spent in the RF power amplifier from the cluster head to the base station, T is the data gathering cycles, E_f is the energy spent per packet, n_0 is the number of nodes, n_1 is the number of cluster heads d is the distance from the base station

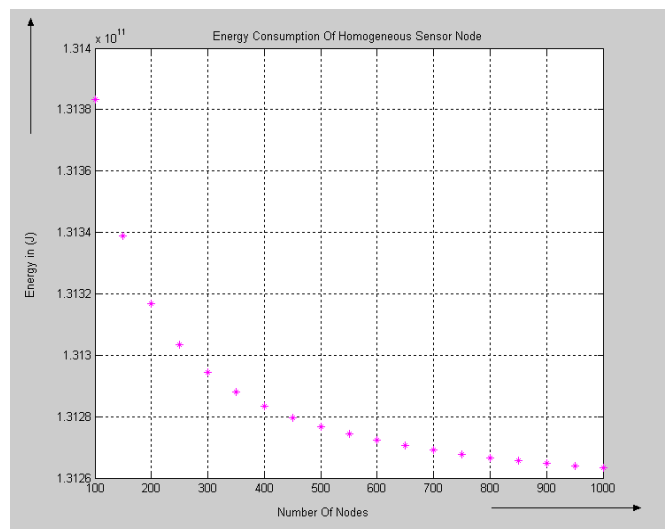

Figure 6 Energy consumption with respect to no. of nodes in homogeneous network.

- To evaluate the performance of heterogeneous sensor networks

In the heterogeneous sensor networks, the total energy consumption is obtained by combining the energy consumed by cluster heads and non-cluster heads. Thus, the total energy consumed by heterogeneous sensor networks is given by $E_I = E_{CH}$ (cluster heads) and $E_0 = E_{NCH}$ (non-cluster heads) in [8]. Thus $E_{Total} = E_{CH} + E_{NCH}$.

Where,

$$E_1 = T \left(\frac{n_0}{n_1} (l_1 + E_f) + (l_2 + \mu_2 d^4) \right),$$

$$E_o = T \left(l_1 + \frac{\mu_1 A^2}{n_1} \right)$$

Hence,

$$E_{CH} = T \left(\frac{n_0}{n_1} (l_1 + E_f) + (l_2 + \mu_2 d^4) \right),$$

$$E_{NCH} = T \left(l_1 + \frac{\mu_1 A^2}{n_1} \right)$$

A is the radius of the region, l_1 is the energy spent in the transmitter electronics circuit within a cluster, l_2 is the energy spent in the transmitter electronics circuit from the cluster head to the base station, μ_1 is the energy spent in the RF power amplifier within the cluster, μ_2 is the energy spent in the RF power amplifier from the cluster head to the base station, T is the data gathering cycles, E_f is the energy spent per packet, n_0 is the number of nodes, n_1 is the number of cluster heads d is the distance from the base station

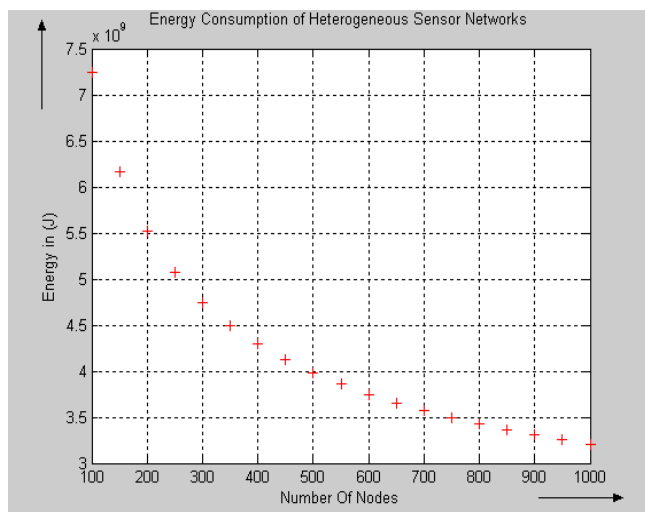

Figure 7 Energy consumption with respect to no. of nodes in heterogeneous network.

6. CONCLUSION

The “MEMS” technological trends of minor devices with high functionality, greater connectivity, and energy consumption in wireless sensor networks. Also, the MEMS are an enabling technology through optical communication components, sensing, and micropower generation. We presented the protocol stack combines power and routing awareness, integrates data with networking protocols, and communicate

power efficiently through the wireless medium. Reducing the energy of communication in wireless microsensors demands that each aspect of communication, such as the protocol and MAC layer is tailored to the application. Therefore, the results show that on the average, the energy consumed using the heterogeneous sensor network is lesser than the homogeneous sensor network. Hence the network performance of heterogeneous sensor network is improved..

REFERENCES

- [1] www.eecs.berkeley.edu/~binetude/course/eng298a/dust.pdf.
- [2] Sukun Kim, Rufus McLain, "Dust Networks",MBA 290/ENG 298A – Introduction to the MOT.
- [3] http://www.businesswire.com/portal/site/home/my-business-wire/
- [4] https://en.wikipedia.org/wiki/Dust_Networks#cite_note-1.
- [5] V. Raghunathan et al., “Energy-Aware Wireless Microsensor Networks,” IEEE Sig. Proc. Mag., vol. 1, no. 2, Mar. 2002, pp. 40–50.
- [6] W. B. Heinzelman, A. P. Chandrakasan, and H. Balakrishnan, “An Application-Specific Protocol Architecture for Wireless Microsensor Networks,” IEEE Trans. Wireless Commun., vol. 1, no. 4, Oct. 2002, pp. 660–70.
- [7] Vivek Mhatre, Catherine Rosenberg, “Homogeneous vs Heterogeneous Clustered Sensor networks: A Comparative Study”, Proceedings of IEEE International Conference on Communications (ICC’04), Paris, France, vol.6, pp.3646-3651, June 2004.
- [8] P.Samundiswary,Padma Priyadarshini and P.Dananjayan, “Performance Analysis of Homogeneous and Heterogeneous Sensor Networks”, MASAUM Journal of Computing, Vol. 1 No.3, October 2009.
- [9] VANÇIN, Sercan, and Ebubekir ERDEM. "Design and Simulation of Wireless Sensor Network Topologies Using the ZigBee Standard." *International Journal of Computer Networks and Applications (IJCNA)* 2.3 (2015): 135-143.
- [10] Merlyn, A. Anuba, and A. Anuja Merlyn. "Energy Efficient Routing (EER) For Reducing Congestion and Time Delay in Wireless Sensor Network." *International Journal of Computer Networks and Applications* 1.1 (2014): 1-10.
- [11] Tuna, Gurkan, Resul Das, and Ayse Tuna. "Wireless Sensor Network-Based Health Monitoring System for the Elderly and Disabled." *International Journal of Computer Networks and Applications (IJCNA)* 2.6: 247-253.
- [12] Resul Das, Gurkan Tuna, Ayse Tuna, “Design and Implementation of a Smart Home for the Elderly and Disabled”, International Journal of Computer Networks and Applications (IJCNA), 2(6), PP: 242-246, 2015.
- [13] Prachi, “A probabilistic Key Management Protocol based on Kryptograph for WSN”, International Journal of Computer Networks and Applications (IJCNA), 2(2), PP: 76-83.

Author



Mr Suvendra Kumar Jayasingh received the Bachelor of Engineering (BE) in Computer Science and Engineering degree from VSSUT, Burla (Formerly UCE, Burla), India. He received the Master of Technology degree in Computer Science and Engineering from JRN RVU, Udaipur, Rajasthan, India. Since August 2005, he has been a Faculty in the Department of Computer Science in Institute of Management and Information Technology(IMIT),Cuttack, India. He

is having around 13 years of teaching and research experience. His research interests include Soft Computing, Machine Learning, Data Base Management System, Algorithm Design and Analysis, Operating system and Data Structures.